

# BRAWLER<sup>®</sup>

[WWW.GPXTIRE.COM](http://WWW.GPXTIRE.COM)

## RUBBER CUTTING EDGES

Brawler Rubber Cutting Edges are engineered to outperform. Combining a unique design and unique physical properties, Brawler Rubber Cutting Edges truly are “cutting edge”.

### FEATURES & BENEFITS

- ① Engineered using an abrasion and chunk resistant Mining Rubber Compound for extended wear.
- ② Designed with an enhanced shape to provide an increased service life.
- ③ Manufactured in 3 lengths and a patented universal mounting system allows for fitment on most bucket lengths.
- ④ 6” rubber thickness.
- ⑤ 2” tapered edge to aid in scraping low loads and to protect flooring.

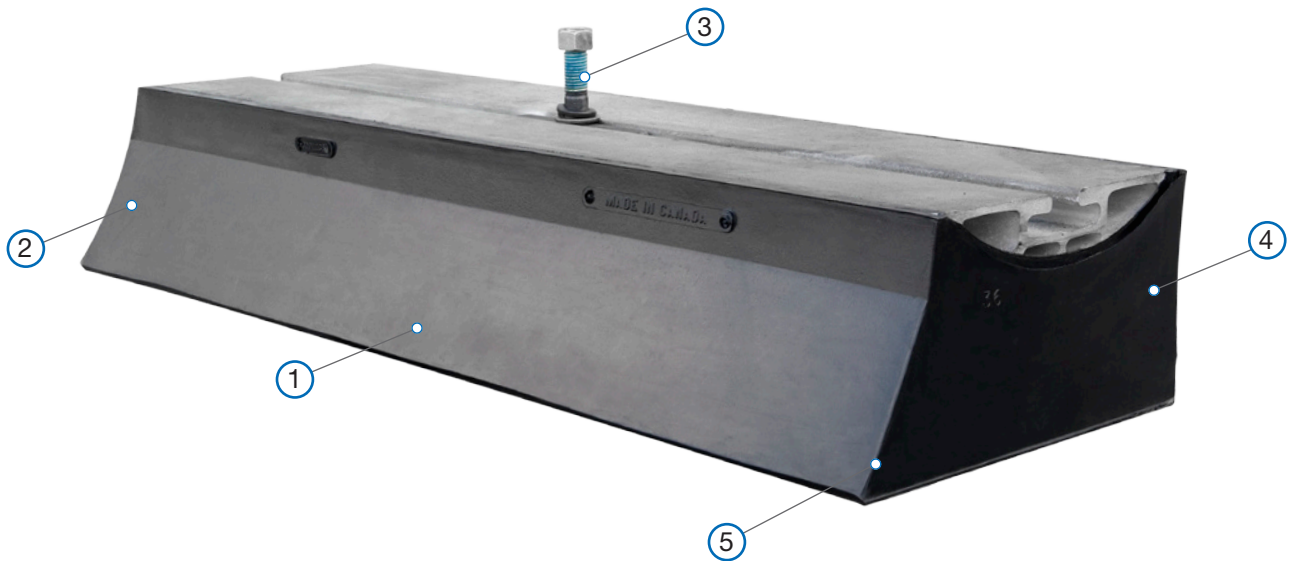

# BRAWLER<sup>®</sup> [WWW.GPXTIRE.COM](http://WWW.GPXTIRE.COM) RUBBER CUTTING EDGES

The Rubber Cutting Edges are available in 3 length options – 36", 40" and 48". The unique patented T-Shaped fastener system of the Rubber Cutting Edges can be combined to fit most bucket sizes. The outside width of the bucket will determine the specific sizes and quantities of segments required. The quantity of fasteners depends upon the number of mounting holes on a given bucket. (See below for examples). If this general guide does not cover the specific customer situation, please contact your sales representative for assistance.

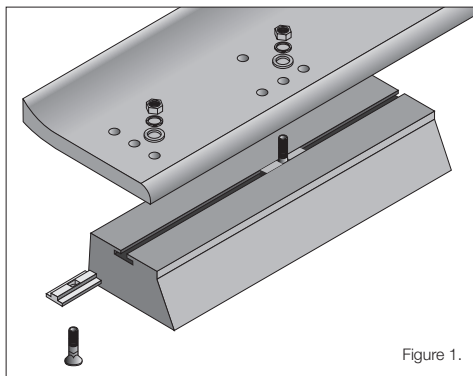

The Rubber Cutting Edge Fastener System uses a patented T-Shaped fastener that can accommodate most bolt patterns found on buckets. A small number of individual section lengths can be combined and arranged to suit all bucket widths. (Fig. 1)

Available in 5/8", 3/4", 1", and 1-1/4" fastener assemblies. Bolt hole size must be measured when fasteners are ordered. (Fig. 2)

